

# Construction of a Distributed Online Journal Editing System

Keizo OYAMA, Noriko KANDO, Shin'ichi SATOH

National Center for Science Information Systems  
mailto:{oyama,kando,satoh}@rd.nacsis.ac.jp  
http://www.rd.nacsis.ac.jp/~oyama/

## Abstract

In the online journal project conducted by NACSIS, an online publication system and an electronic editing system are being developed in order to support for Japanese academic institutions to realize online publication of scholarly journals. In this paper, the authors describe the outline of the project, the overall configuration of the developed system, and the functions and the implementation method of the electronic editing system. The editing system is to produce electronic journals at each institution, and is designed to be adaptable to its various requirements.

## Keywords

Online journals, Online publication, Electronic editing, Document processing, Document management, Process management, Online reviewing, Online submission.

## 1 Introduction

In the era of networked information, mechanisms to support efficient and prompt production and distribution of research information are crucial to maintain academic research activities. Major academic societies and publishers in the United States and Europe have been operating online journal services for years (e.g. ACM[1], AIP[2], Elsevier[3], High Wire Press[4]).

The National Center for Science Information Systems (NACSIS) is providing researchers with an information retrieval service of fulltext of scholarly articles (NACSIS-IR), and with an electronic library service of scholarly journals (NACSIS-ELS). For these services, however, the contents are produced from conventional media. Therefore, the measures we can take to make the services more useful and more prompt are quite limited.

On the other hand, many institutions are suffering from increasing costs of journal publication, decreasing number of subscribers, necessity for countermeasure to global movement of online journals, and so on. However, many of them do not have sufficient financial strength or technical background to cope with such situation.

Consequently, it is important for NACSIS to establish closer collaborative relationship with academic institutions in promoting introduction of electronic methods into their editing and publishing processes.

In order to answer to these requirements, NACSIS has executed research and development on electronic

processing for editing and publishing of scholarly journals for several years.

With such a background, NACSIS is conducting "A Project for Development and Construction of an Editing and Publication System for Online Journals" (NACSIS-OLJ), funded by the Ministry of Education, Science, Sports and Culture. The project began in fiscal year 1998 and extends for four years.

The purpose of the project is to promote online publication of scholarly journals by means of supporting academic institutions in constructing an overall system which covers from authoring, submission, reviewing, document editing, layout, through online publication.

In the following sections, overview of the project and concept of the overall system configuration are shown, then detailed description about implementation of the electronic editing system is given.

For further information on the project, a web page of the research and development[5] points to the latest status and other topics. Some useful resources are also available from the page.

## 2 Overview of the Project

The aims of the project are, to construct a comprehensive online journal publication system and its operational environment, in order to realize prompt publication and distribution of research results over the Internet, to build a distribution hub of scholarly articles in Japan, and to provide one-stop-shopping of information required to research activities.

In the project, we have set several conditions as follows in order to realize a working system within a short term.

- (1) The targets of the project are limited to scholarly journals published by academic institutions and universities, with focuses put on the transactions at the first stage.
- (2) Printed version and online version should be produced simultaneously at almost the same cost as the conventional process.
- (3) The system should be adaptable to various requirements of many academic institutions.
- (4) System modules such as document editing tools should be composed of existing components (e.g. commercial softwares, free softwares) as far as possible.
- (5) The overall system should have a configuration functionally distributed over the Internet in order

to let small-sized institutions utilize the system efficiently.

- (6) The subsystems which cover from submission through production are to be distributed and operated at respective academic institutions, regarding the variety of their sizes and editing processes.
- (7) The subsystem which performs online publication is to be operated by NACSIS, regarding the scale merits and the convenience of the subscribers, as well as system operation load of each institution.

At the beginning of system development, in cooperation with several academic institutions, we surveyed their current status from several aspects described in the next section.

Investigating the survey results, it becomes clear that there is so much variation in editing organization, in review process, and in document processing environment.

Although several institutions have already developed partial component systems (e.g. a review process management system, a publication schedule management system) for their own uses, they are not flexible enough to adapt to the variation.

There are a few existing commercial products, which are used at academic publishers in the United States. However, they cannot be applicable to Japanese academic institutions, not only because their user interfaces are in English, but also because they are designed to be used in well-organized publishers.

Thus, we reached a conclusion that, in order to promote for academic institutions to produce electronic versions of their journals, a new flexible online journal editing system specialized to academic institutions is crucial, as well as an online publication system. Therefore, we decided to develop a comprehensive and highly customizable online journal system.

The overall system is designed as two subsystems: an electronic editing system which is operated by each institution, and an online publication system which is operated by NACSIS and is shared and used by academic institutions. We also developed a common document format for data exchange among system components.

The electronic editing system has functions for producing electronic journals. NACSIS is developing its common functions and provides it for each academic institution. Each institution adds and modifies functions to meet its unique requirements, and operates the system.

The online publication system has basic functions for publishing electronic journals online through the Internet, and various additional functions. NACSIS is developing and will operate the system, and will provide academic institutions with its utility.

The common document format is a simplified document structure defined as an XML DTD, and is used

for exchanging textual information between system components. The XML document instances are used to extract bibliographic data or reference items from document files, or to add fulltext search capability to the online publication system.

As the future plan, after the developed editing system will be experimentally introduced to the cooperating institutions and test and tuning will be executed, the system will be provided for any requesting academic institutions. Development for extended functions as well as for coping with new information technologies will also be continued, taking opinions and requirements of academic institutions into consideration.

### **3 Current Status of Editing Process**

As a preparation for designing the editing system, we surveyed the current status of editing and publishing of scholarly journals in cooperation with several academic institutions in Japan. The survey items include classes and types of articles, organizations for editing and publishing, production processes, information processing environment of the institution members. The survey results relating the design of the electronic editing system are described hereafter.

It should be noted that the research fields of the cooperating institutions were, 5 in sciences, 3 in engineering, 1 in life sciences, 1 in social sciences, and all of them are aggressive at electronic editing and publishing in respective fields.

#### **(1) Classes and types of articles**

Though names are different among institutions, all articles are classified to contributed papers or invited papers. The article types also have various names, but most of them fall into one of regular papers, letters, short notes, reviews, or commentaries.

#### **(2) Members and roles of editorial boards**

A chair person and regular members (editors) are common to all institutions. Some institutions have vice chairs, guest editors, and/or associate editors. There are a few cases that committees for several fields are organized under supervising editorial boards. In every institution, the editorial board has roles of selecting a responsible editor and one or two reviewers, and of deciding acceptance, while the allocation of roles differs slightly among institutions.

#### **(3) Organization of editing secretariats**

There are three types of organizations: an editing secretariat is organized in the institution; an independent editing secretariat is organized for publishing a joint journal; and a independent publisher acts as a secretariat. Further, in some cases, they commission the works to external agencies, partly or totally.

#### **(4) Construction of databases**

Although the status varies from institution to institution, it seems that each institution is constructing a member database, a reviewer database, and an

article management database as a set. About a half of surveyed institutions commission the operation to agencies.

#### (5) Reception of submitted articles

The submission of articles are directed to one of the editing secretariat, the editorial board chair, or the editorial board members, depending on journals. All the institutions receive paper manuscripts, and a half of them also receive LaTeX, word processor files, plain text and others by FD and/or e-mail. Almost all institutions require the authors to fill in submission forms.

#### (6) Selection of reviewers and reviewing procedures

In all institutions, peer reviewers are selected by editorial boards or by editors. Articles and review forms are handled in paper form in all institutions at present. A few institutions adopt parallel review by two reviewers.

#### (7) Layout and proofreading

A half of the institutions use LaTeX for layout of articles. The others seem to be using peculiar systems to the printers. Author proofreading varies between one to three times depending on journals.

#### (8) Commission of works to printers

A half of the institutions commission all the works after reviewing to printers. All but one of the others commission the works from typesetting through printing to printers.

#### (9) Online publication of articles

Almost all the surveyed institutions make tables of contents public, and half of them make bibliographies and abstracts public, without restriction. About half of them also make fulltext of articles accessible online, all but one of them restricting to members, and the rest with limiting the publication term.

### 4 Overall System Configuration and the Functions

The overall system consists of electronic editing systems and an online publication system. The electronic editing system provides various functions for secretariat staff and related people of each academic institution. The online publication system provides the contents of journals and related functions for public users. The systems and all the users are interconnected with the Internet, as shown in figure 1.

#### 4.1 Electronic editing System

Users of the electronic editing system are secretariat staff, editors, reviewers, authors, and so on. The system is used to execute all the processes from reception of submitted articles through production of typesetting data for printing and electronic documents for online publication at each academic institution. It has various common functions: management of users (e.g. system administrators, editorial board chairs, editors, secretariat staff); databases

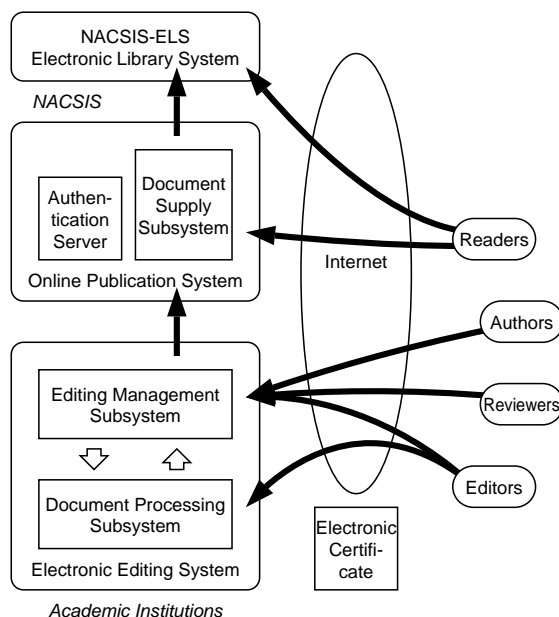

Figure 1. Overall system configuration.

(document management, institution member management, reviewer management); process management (e.g. reviewing, document editing, layout, proofreading, outputting for printing and online publication); reception of submitted paper (postal mail / e-mail / FTP / WWW); review process support (e.g. reviewer selection, online reviewing); document editing and layout (utilizing word processors / desk top publishing softwares); output (printed and electronic documents for reviewing, proofreading, printing, and for online publication); data up-loading for online publication; reception of subscription application.

Based on these functions, each academic institution can construct a customized electronic editing system. Figure 2 shows an example flow diagram of editing process. The flow varies depending on scale, organization, and research field of the institution. For example, English proofreading is optional; the roll of the chairperson of editorial board varies; author proofreading may be inserted in document editing stage or in layout stage; document editing and layout may be processed within the institution or by an external company such as a printer. There are some cases that editorial boards have two level hierarchy comprising a general committee and branch subcommittees.

Each institution also selects document file formats and processing tools, considering the authors' information processing environment, characteristics of research fields, experiences, and conventions. The system is designed to adapt to them as flexibly as possible.

Because many of academic institutions have already introduced various computers, and because secretariat and editors, who promote and support system construction, have variety of experiences and

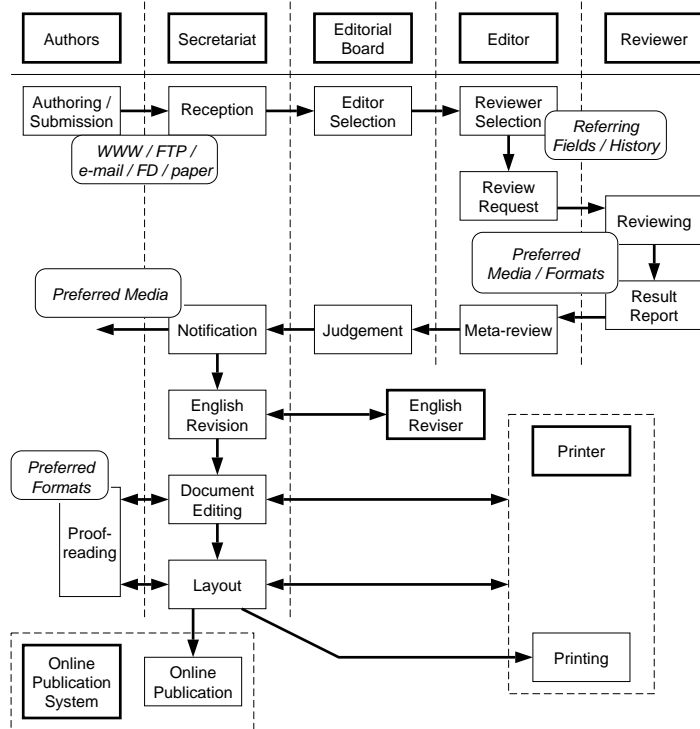

**Figure 2. Flow diagram of editing process.**

know-hows, the electronic editing system is required to run on as many platforms as possible. Being at the first stage of the development, we selected two platforms: a Windows NT/95/98 series and a SPARC-Solaris series. At the next stage, Linux and Macintosh will also be included in the scope.

The detailed configuration of the electronic editing system will be discussed in the next section.

#### 4.2 Online Publication System

The online publication system stores and manages articles of various journals, and provides them for subscribers through the Internet. The system is operated by NACSIS and is shared by many academic institutions. It has various functions as follows: application for subscription of online journals; issuance and management of electronic certificates; user authentication, user management, and access control; document supply; browsing of journal titles and tables of contents; bibliography / fulltext search; current contents alert; server-side histories / bookmarks, multimedia publication; citation link navigation; online forums; journal administration (for institutions); and linkage with NACSIS-ELS.

Based on these functions, each institution can schedule date and term of publication for each online journal, and can set publication extents (e.g. search / display of bibliography / fulltext) for respective subscription privileges (i.e. personal subscribers, tentative subscribers, organizational subscribers, and non-subscribers). Automatic archiving service to the NACSIS-ELS will be provided in the near future.

The system also provides administrative staff with

functions to receive subscription applications, to register subscribers, to upload new issues, and to acquire utilization statistics remotely via the Internet.

### 5 Distributed Editing System

The electronic editing system has two levels of distributed processing. The upper level is distribution among institutions, and the lower level is distribution within each institution. In order to realize the upper level distribution, it is important to implement a system which many institutions can adopt. On the other hand, the lower level distribution is required in order to implement heterogeneous document processing environment efficiently. Therefore, it is important to build a mechanism for flexibly incorporating various functional modules including hardware.

In order to satisfy these requirements, we adopted a system configuration consisting of an editing management subsystem and a document processing subsystem, as shown in figure 3. Among the functions described in the subsection 4.1, the editing management subsystem implements management functions having no direct relations to respective document instances, and the document processing subsystem implements functions for processing respective document instances. The editing management subsystem supports the upper level distribution, and the document processing subsystem supports the lower level distribution.

In each academic institution, a server to run an editing management subsystem and clients for secretariat to operate are installed, interconnected with a local area network. All the editing operations by the secre-

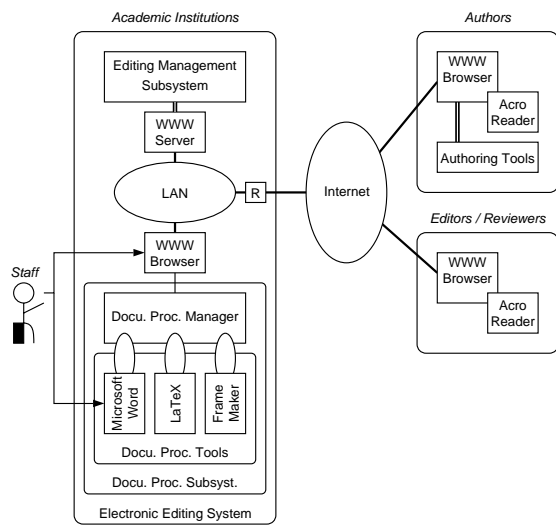

**Figure 3. Configuration of the electronic editing system.**

tariat are executed on or through the clients. The users (e.g. authors, editors, reviewers) use the electronic editing system by accessing the server through the Internet.

### 5.1 Interaction between the subsystems

All functions of the editing system are executed under the control of the editing management subsystem through CGI of an httpd running on the server. However, most of the document processing functions have to be run on the clients, initiated by the editing management subsystem.

The clients may differ in hardware or in operating systems (as personal computers and workstations), even in a single institution. A necessity will arise to introduce a new type of clients in accordance with the progress of information processing technology. Considering such circumstances, we decided to implement all the interfaces between the server and the clients using HTTP and CGI. A conceptual diagram

of processing flows between the server and the clients are shown in figure 4.

Since managemental functions are performed by the editing management subsystem alone, users can operate interactively through WWW browsers. When a user is to execute a document processing tool from the client, the user first accesses the editing management subsystem, then select a document and an operation. The processes hereafter are different for a local user and a remote user. For a remote user, the document processing manager is directly run from the editing management subsystem, then the document processing tool is executed and the result is returned to the editing management subsystem. On the other hand, for an local user, first a document processing specifier file is sent from the editing management subsystem via CGI, next the document processing manager is run as a helper application, which is specified by the content type of the HTTP header, then the document processing tool is executed. When the execution finishes, the document processing manager notifies the editing management subsystem of the processing result by sending a report to the server CGI.

Though It is conceptually possible for a remote user to execute document processing tools on the client, it is unrealistic because the document file must be transferred over the Internet each time it is processed. In order to enable remote document processing, we are considering to develop a function to check the document file out, to execute document processing tools locally, then to check the resulting document file back in the system.

### 5.2 Editing management subsystem

The editing management subsystem holds databases of document management information, reviewer information, institution member information, and performs process management, editorial board

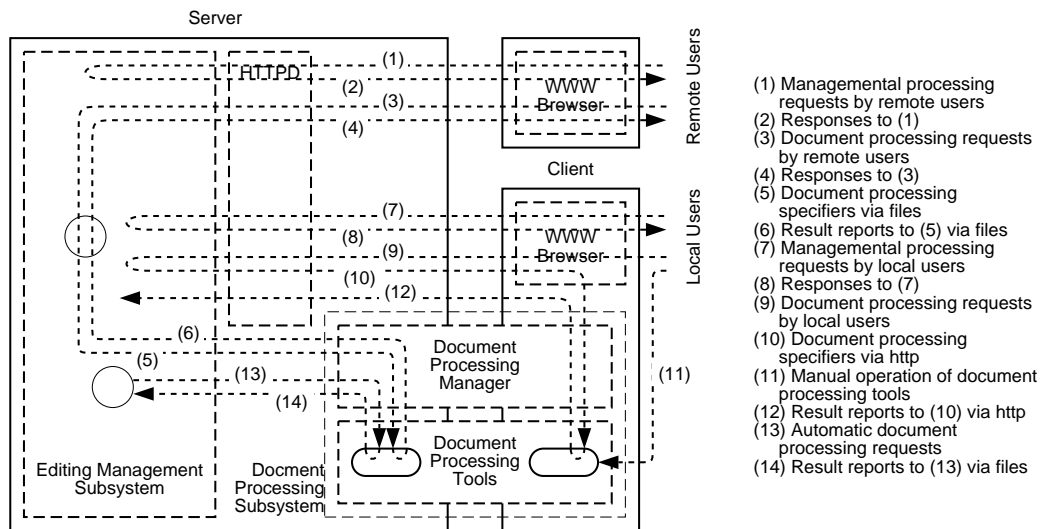

**Figure 4. Overview of processing flow between the server and the clients.**

support, and so on. Based on the investigation on the cooperating institutions, we designed the subsystem to include most of the managerial functions required by many institutions. Each institution can use the subsystem by selecting its necessary functions by specifying parameters. In this way, distributed electronic editing systems, which has a common interface to the online publication system, can be realized and operated at respective institutions.

As a function to cope with variation of organization, user groups (e.g. system administrators, editors, secretariat) can be defined to the system and can be assigned the execution privileges of each processing stage. Each user belongs to one or more groups according to the user's role. The user uses an electronic certificate to get authentication, and can execute only the processes which are permitted to the belonging groups.

The subsystem performs managerial functions as follows:

- Receipt of submitted articles: receives documents submitted via postal mail, e-mail, FTP, WWW, etc.; produces managerial records; and registers the article to the system.
- Document management: stores status of editing and reviewing of documents, assigned editors, information of submitters, and so on; and retrieves them on demands.
- Review process support and management: supports reviewer selection by searching reviewer candidates with research fields and others from a reviewer database, and by displaying profiles such as research fields and review histories; and provides a mechanism to send review requests and to let reviewers access the documents online.
- Process management: manages overall editing process of each issue of each journal, including status and deadline of document editing, layout, proofreading, and production of typesetting data.
- Online publication management: uploads and registers electronic documents to the online publication system, and manages publication schedule and publication policy for respective subscription privileges.

### 5.3 Document processing subsystem

The document processing subsystem executes a series of document processing from reception of submitted articles through production of typesetting data for printing and electronic documents for online publication. It consists of a document processing manager and various document processing tools attached to it.

Document processing may require various tools at respective processing stages even in one institution. The subsystem has to control several tools when different document file formats exist in parallel. In some

cases, heterogeneous hardware and operating system environment is needed to fulfill the document processing requirements. It should also be considered that, depending on the trigger event, some kinds of document processing are appropriate to be executed on the server.

In order for these complexity not to affect the editing management subsystem, the document processing manager encapsulates processing which depends on document file formats and processing tools of respective document instances, and provides the editing management subsystem with an abstract interface consisting of document identifiers and document processing specifiers. It is also considered that, in order to utilize various existing softwares as far as possible, the document processing manager interfaces to the document processing tools with primitive command line parameters and return codes.

#### (1) Document processing tools

Document processing tools are software modules which execute real processing of respective editing stages according to document file formats. They are composed by introducing word processors, desk-top publishing systems, text formatters, etc. available in the market or as free softwares, and then developing and incorporating tools and modules satisfying the demands of the institution and the field. While the current targets of development are MS-Word, FrameMaker, LaTeX, and Adept Editor (XML editor), other document processing products can easily be incorporated if they can be initiated and monitored from command line scripts. Followings are examples of tools and modules developed for the document processing subsystem.

- Templates and style files for authoring, document editing, and layout
- Format checkers for authoring and document editing
- Packing and unpacking tools for submission
- Tools to extract structured text for producing article management records, citation linking, and fulltext search
- Document output tools for reviewing, proofreading, typesetting, and online display

Followings are examples of document file formats which document processing tools can handle.

- Submission: MS-Word, LaTeX, XML, paper
- Review: PDF, paper
- Online publication: PDF, XML, HTML (converted from XML on the fly)
- Typesetting data: PostScript, MS-Word, LaTeX

#### (2) Document processing manager

The document processing manager manages stor-

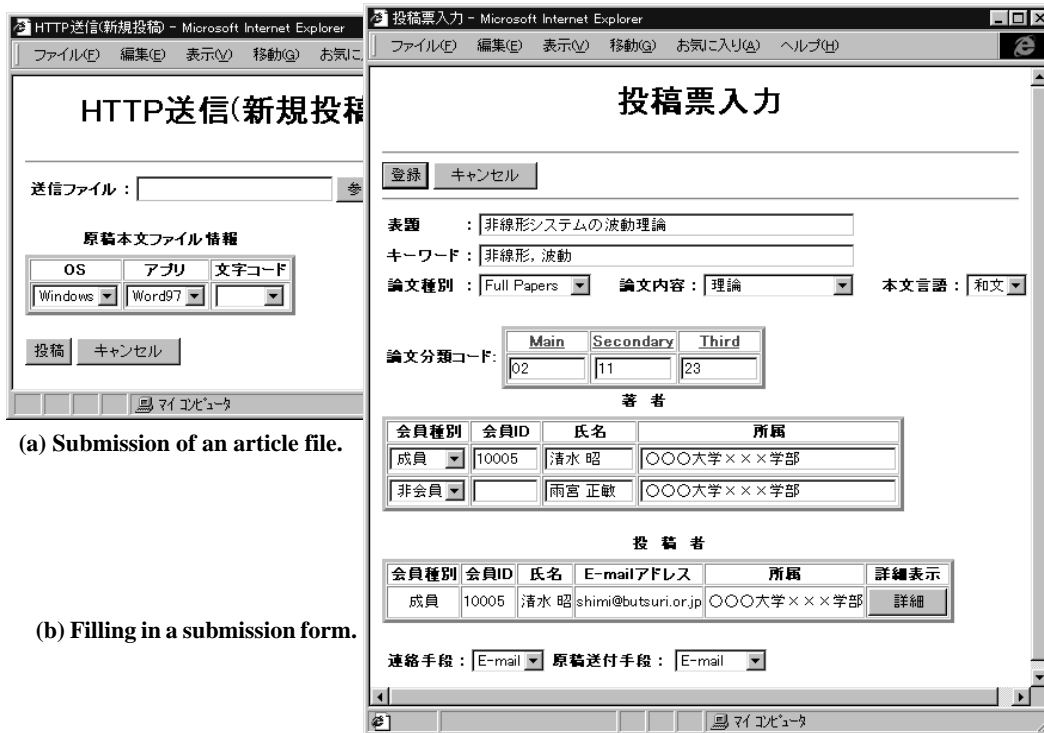

Figure 5. An example of submission operation via WWW.

age locations, document file formats, and versions of respective document files, and initiates and monitors appropriate document processing tools according to the stages of editing process. We developed a new document processing management method for realizing these functions. In this method, complex dependencies and conversion procedures between document classes are described in a document processing definition as rules. For describing the dependencies, not only document processing stages, document file formats, and output document formats, but also versions updated by manual operations (e.g. submission of revised documents, manual layout operation) can be specified. Analyzing the definition and applying it to document instances, the manager provides flexible and highly abstract document processing functions.

#### 5.4 System view of the users

Usages of the electronic editing system from viewpoints of users are described hereafter.

##### (1) Authors (Submitters)

An Author writes an article manuscript using the style file or the template, then makes a submission file using the packing tool and send it via postal mail, e-mail, FTP, or WWW. For instance, in a case of WWW submission, the author accesses the WWW server of the institution, fills the file name and some required items in the form, and submits it, as shown in figure 5. Then, a submission form is automatically generated and displayed. When the author makes corrections and additions and submits the form, the operation is completed.

Notifications of reception confirmations, review results, inquiries, proofreading and others are delivered via e-mail afterwards. The author can confirm status of the submitted article at any time by accessing the WWW server and giving the password and the receipt number.

##### (2) Editorial staff (Secretariat)

When the editorial staff accesses the WWW server of the editing management subsystem and selects an operation from the shown menus, a list of documents waiting for processing and applicable operations for respective documents are shown. By selecting an operation, processing modules necessary for the operation are run. All the editorial operations are performed through the same interface.

For an example of document editing and layout, as shown in figure 6, when one specifies an operation, several items (e.g. the reception date, the running title, and the document identifier) are embedded into the document file, then tools like a word processor or a desk top publishing software is activated and the document file is open. When the operation is finished, the management information is updated automatically.

##### (3) Editors (Editorial board members)

An Editor accesses the editing management subsystem using a WWW browser through the Internet. The interface for selecting articles and operations are the same as that for editorial staff.

For the operation of reviewer selection, for instance, specifying a field and other conditions in a reviewer search form, a list of members matched in the reviewer database is shown. The editor selects candidates from the list, considering the detailed in-

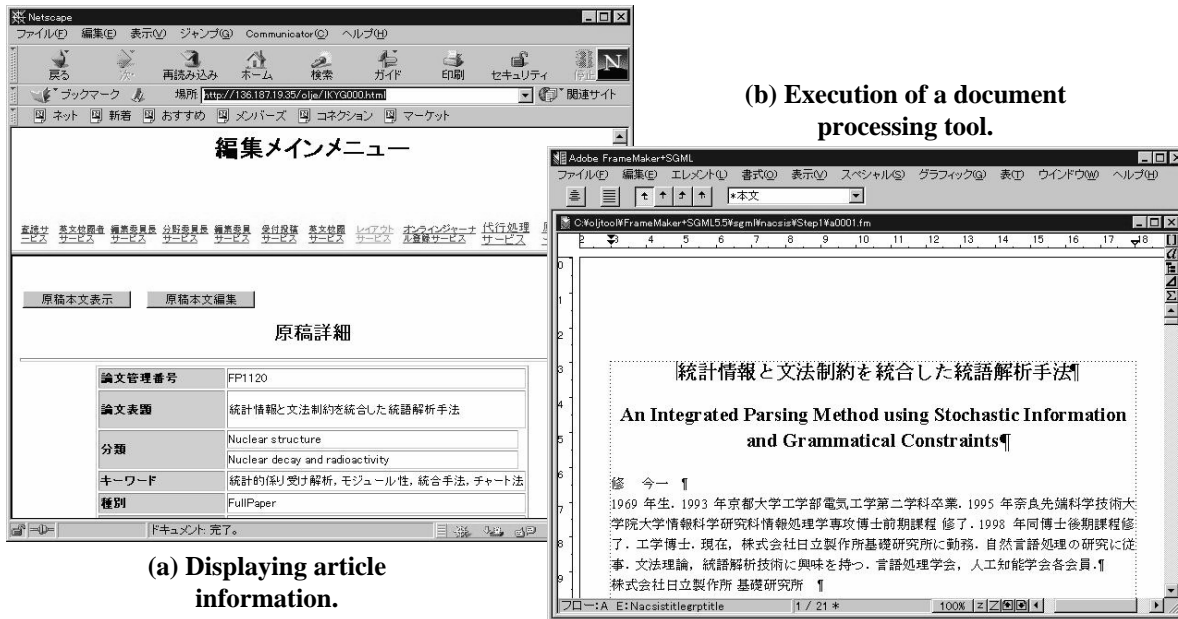

Figure 6. Document processing operation.

formation (e.g. affiliation, research fields, review history) displayed for each candidate. When the editor finally selects a designated number of candidates, a review request form is presented. Checking the name, affiliation, deadline, and so on, and submitting the form, the operation is finished and the review request message is sent via an appropriate media automatically by the system.

#### (4) Reviewers

The reviewer database stores preferences of communication media and acceptable document formats as well as other personal information of respective review members. The system automatically selects appropriate processing and media for messages and reviewing documents according to the information. If a reviewer prefers postal mails, for example, the review request message is output to a printer at the secretariat, then the staff will send it by postal mail.

For instance, when a reviewer receives the request message via e-mail and accesses the editing management subsystem through a WWW browser, the reviewer can view the list of requested articles. Selecting an article, a reply form is presented including the title, abstract and others. If the reviewer consents, the reviewing document in PDF format becomes accessible.

The review result report is also performed by a series of operation, first selecting an article from a list of reviewing articles, then filling the review result report form with the judge and the comments and submitting it.

## 6 Concluding remarks

The project described in this paper is still in progress, and changes are due according to the changes of circumstances before the actual operation.

Because of the timing and the space, the technological features of the implementation or the advanced functions proper to online journals are not described fully. We will find other occasions to describe about them.

From a viewpoint of project administration, requirements of respective institutions were not incorporated enough because of limited time in the fiscal year 1998. We are planning to introduce the system to cooperating institutions for experimental uses and to polish it up, then to provide it for any requiring institutions by the end of fiscal year 1999. We are also going to continue developing representational extension such as multi linguality and extended characters, mathematical and chemical formula, as well as coping with the transition of publication media from paper to online.

Realization of multilateral links among online journal is another important issue. We are going to start talking with other domestic and overseas organizations which are operating online journal services.

## References

- [1] "ACM: Digital Library", <http://www.acm.org/dl/>
- [2] "American Institute of Physics - Physics Information NetSite", <http://www.aip.org/>
- [3] "Elsevier Science: Electronic Services", <http://www.elsevier.com/homepage/elecserv.htm>
- [4] "HighWire Press", <http://highwire.stanford.edu/>
- [5] "NACSIS Online Journal Project - Development", <http://www.rd.nacsis.ac.jp/olj/index-j.html> (In Japanese)